

**Standard Construction and Materials**

- FRAME:** 18-GA. galvanized steel, channel or flanged type.
- BLADE:** 18-GA. galvanized steel. Blades approximately 2 1/8" on centers.
- SCREEN:** (When indicated)  
1/2" mesh, 19-GA. galvanized steel (.041").
- CONSTRUCTION:** Riveted and/or welded for maximum service.

**Options**

- Frames and Blades of other gauges
- Other materials - Stainless steel, Copper, Aluminum, etc.
- Finishes - Enamels, Epoxies, etc.
- Screens - Insect screen 19/16 aluminum mesh.
  - or- 1/2" flattened aluminum, .051",
  - or- 1/4" sq. mesh, 18-GA galvanized steel, .047",
  - or- 1/2" sq. mesh, 18-GA stainless steel, .047",
  - Others available.

**Notes**

1. Nominal deductions will be made to the opening size given.
2. Approximate shipping weight is 5.0 lbs./sq.ft.

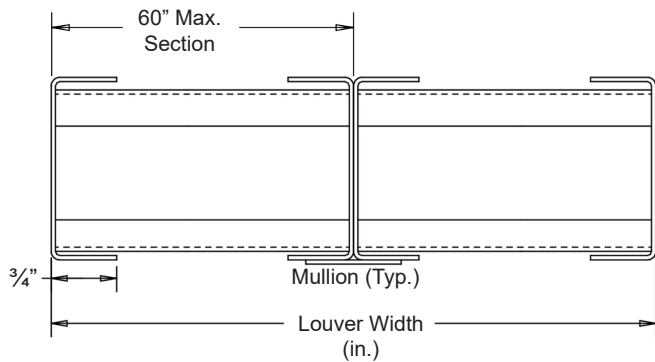
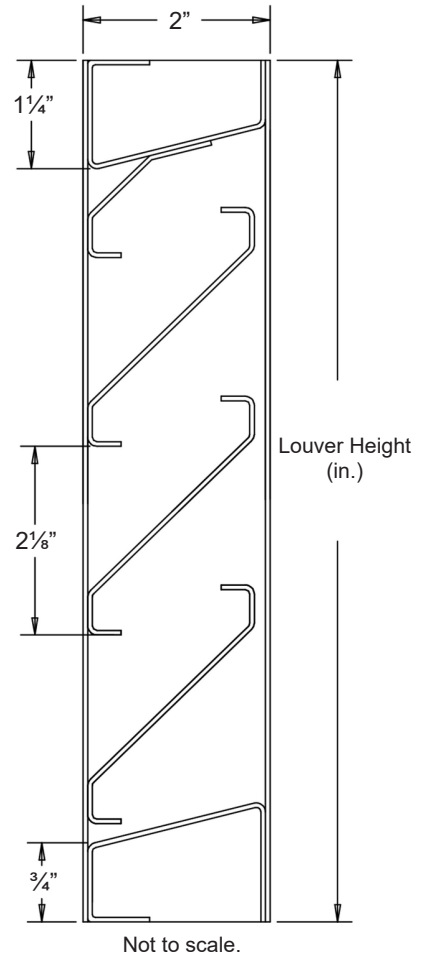

Flange Frame Available

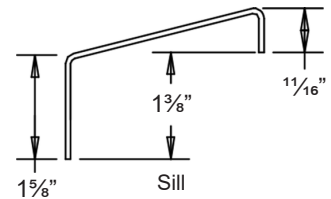
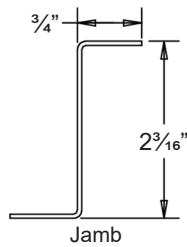
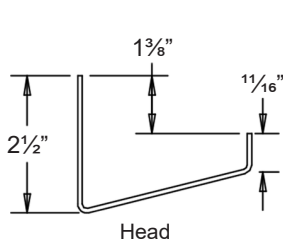

									
Item #	Qty	Width	Height	Width	Height	Mullion	Type	Location	
		Opening Size		Louver Size			Screens		Union Made
Arch. / Eng.:						EDR:		ECN:	Job:
Contractor:									
Project:						Date:		DWN:	DWG:

In the interest of product development, CESCO Products reserves the right to make changes without notice.



450 Riverside Dr • Wyalusing PA, 18853  
 Phone: 570-746-1888 • Fax: 570-746-9286  
 www.cescoproducts.com